

MCU500 Mobile Locator and Control Unit

Hardware Reference Manual

Part Number 100-00191
Revision 1.01

Copyright © 2000-2001 by Thorcom Systems Limited.
ALL RIGHTS RESERVED

This document may not be copied in part or in whole, stored on magnetic tape or disc or in an information retrieval system, or used in any way without permission from the publisher.

The information contained in this document has been carefully checked and is believed to be accurate and reliable, however, no responsibility is assumed for inaccuracies. Thorcom Systems Limited reserve the right to make changes to this document and the associated product in line with its policy of continued improvement. Thorcom Systems Limited does not assume any responsibility for direct or consequential damage to, or loss of, property or income through the use or inability to use this product.

The equipment described in this document must be installed, operated and maintained in accordance with the written procedures described herein, and should not be used for any purpose that involves the safety of life or limb, and should not form any part of a life support system.

Details and descriptions of the product, methodology and design supplied in this documentation are considered part of the product and are covered by the manufacturer's Intellectual Property Rights. Information provided in this documentation is to allow the customer to use, install and maintain the equipment described and does not transfer any rights to such Intellectual Property Rights, Patents or Copyrights to the customer or any third party.

For further information on this product please contact Technical Support at:

Thorcom Systems Limited
Unit 4
96B Blackpole Trading Estate West
Worcester WR3 8TJ
England, U. K.

Tel: 01 905 756700 (international: +44 1 905 756700)

Fax: 01 905 755777 (international: +44 1 905 755777)

Email: support@thorcom.co.uk
Web Site: <http://www.thorcom.co.uk>

Part Number: 100-00191

Revision: 1.01

Date: 5 April 2001

Reference: \\Pendragon\documents\Manuals\Products\mcu500\Hardware-100-00191-rev-101.wpd

Document Revision History

Date	Revision	Initials	Description
26/11/2000	1.00	MJT	New document
05/04/2001	1.00	MJT	Revised jumper settings and fixed typos

Contents

1. Introduction	1
1.1 Scope of document	1
1.2 Other documentation	1
2. Product variants, facilities and options	2
2.1 Power supply variants	2
2.2 System memory size	2
2.3 Program memory size and type	2
2.4 Enclosure	3
2.4.1 Front panel layout	3
2.4.2 Status LEDs	3
2.4.3 Rear panel	3
2.5 Deep sleep timer	4
2.6 Application firmware	4
3. Installation and operation	5
3.1 Installation	5
3.2 Power connection	5
3.3 Connection to radio communications equipment	6
3.4 GPS antenna selection	6
3.4.1 Standard GPS antennas	6
3.4.2 Alternative GPS antennas	7
4. Interfaces and connectors	8
4.1 Power and input/outputs	8
4.2 COM1 serial port	9
4.3 COM2 serial port	9
4.4 Auxiliary port	10
4.5 GPS antenna connector	11
5. Maintenance and trouble shooting	12
5.1 Removing the PCB from the case	12
5.2 Changing the firmware EPROM/FLASH device	12
5.3 Trouble shooting	13
5.3.1 No response from the MCU500	13
5.3.2 Unit unable to send location updates	13
5.3.3 Unit not correctly programmed	13
6. Jumpers and configuration options	14
6.1 COM2 voltage settings	14
6.2 Analogue input/mode selection	15
6.3 EPROM/FLASH size and type	15
6.4 RJ45 pin assignments	16
6.5 Hardware wake-up timer	16
6.6 COM3 RS232/RS485 settings	17
7. Technical specifications	18
7.1 Electro-magnetic compatibility and electrical safety	19

1. Introduction

This document describes the Thorcom Systems MCU500 mobile locator/control unit. The MCU500 is a high performance, low cost, in-vehicle communications processor with integrated GPS receiver and is designed for automatic vehicle location, fleet management and vehicle telemetry/telecontrol applications.

MCU500 is intended for use on a range of radio communications networks including GSM Cellular, TETRA digital trunked radio, MPT1327 analogue trunked radio and public data networks such as RAM/Mobitex, PakNet and others.

Applications include mobile data and Automatic Vehicle Location (AVL) on a range of radio/communications networks for the Emergency Services (Police, Fire, Ambulance etc.), Public Utilities and Local Authorities, National Transportation and Local Delivery operators, and many other users of wireless data systems.

The AVL capability is provided through the use of an internal GPS receiver, which allows the MCU500 to perform as a high performance vehicle location unit with intelligent 'rules based' position updating.

The unit incorporates a high efficiency switched mode power supply to minimise power consumption and generation of unwanted heat. The modem can operate from 12V or 24V DC vehicle supplies, which includes intelligent power management to protect and control other in-vehicle power systems, and operate for extended periods from batteries, making use of a 'deep sleep' power saving mode. The unit also includes a hardware watchdog timer to protect against lockups or malfunctions when operating in extremely harsh vehicle environments.

1.1 Scope of document

This document is intended for systems integrators, project managers, programmers, and installation/maintenance personnel.

This document details the hardware aspects of the MCU500, interfaces, voltage levels and adjustments and settings. Please refer to separate documentation for operating of the various software/firmware available for the unit - this may vary depending on the communications network and/or application.

1.2 Other documentation

This hardware reference manual should be read in conjunction with the following other documents:

Description	Thorcom Part Number
MCU500 Software Reference	100-00184
Modem Personality Programmer User Manual	100-00185

2. Product variants, facilities and options

This section describes the MCU500 product variants and ordering options.

2.1 Power supply variants

Two versions power supply versions of the MCU500 are available:

Version	Supply voltage range
12V	Operating supply 10.0 to 16.0 volts; for cars and light goods vehicles
24V	Operating supply 20.0 to 32.0 volts for heavy goods vehicles.

Various internal components are installed for 12V or 24V at time of manufacture. The user cannot change the unit between 12V and 24V operation.

WARNING: Connection of supply voltage outside of specification may cause damage to the unit - this is not covered by the product warranty.

2.2 System memory size

The MCU500 can be equipped with two different memory sizes at time of manufacture to suit different applications:

Version	Size (Kb)	Description
Standard	128	Standard unit
Large memory	512	Extended memory for large quantities of data logging

The memory size of the unit cannot be changed after supply.

2.3 Program memory size and type

The MCU500 has been designed to operate with either EPROM or FLASH memory devices in the range 64Kb to 512Kb.

Depending on the application software size and type either EPROM or FLASH may be fitted at time of manufacture. Jumper JP5 selects the size and memory type installed in the MCU500.

2.4 Enclosure

The MCU500 is supplied in a heavy gauge aluminium extruded case which is anodised black.

The front panel has the 12-way Molex connector for power and I/O, the GPS antenna RF connector and four status LEDs. The rear panel has the two 9-way D-types for the serial ports COM1 and COM2 and an RJ45 connector for the

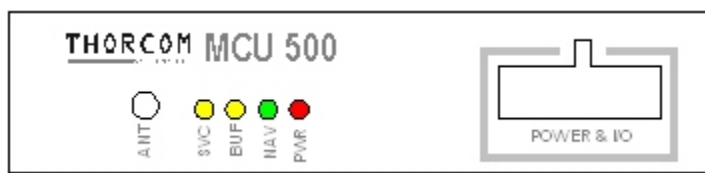

auxillary port.

2.4.1 Front panel layout

The front panel of the MCU500 is shown below:

2.4.2 Status LEDs

The MCU500 has four LEDs used for indicating the status of the locator unit as follows:

Name	Color	Description
PWR	Red	Indicates that the power is applied to the unit and that its is switched on
NAV	Green	Flashing (1 second pulses) indicates that the MCU500 is performing position calculations
BUF	Yellow	Flashes briefly to indicate that a message is being sent or received

Name	Color	Description
SVC	Yellow	Permanently lit to indicate that a good connection is made with the radio device Flashes to indicate that the personality programming is incorrect

2.4.3 Rear panel

The rear panel contains two standard 9-way D-type male connectors for connection to the radio device and for a connection to a mobile data terminal (MDT), or engineering programming equipment. There is a central RJ45 connector which carries a third serial port (with RS232 or RS485 signal level options), and some further digital inputs.

For most applications the mobile data terminal and/or PC is connected to COM1 and the radio bearer is connected to COM2. Consult the software reference manual for further details.

2.5 Deep sleep timer

The MCU500 is equipped with a “deep sleep timer” which allows the unit to conserve power but wake up periodically, determine if events have changed, make a transmission (or transmissions) and then go back to sleep. When sleeping, the unit draws only a few hundred micro-amps from the power source. This permits operation from a battery, for example if the unit were to be installed in an un-powered goods trailer.

The wake up period is configurable using a jumper on the PCB. Please note that not all versions of firmware support use of the deep sleep timer - please consult Thorcom for additional advice.

2.6 Application firmware

The MCU500 hardware can be used to run several different sets of firmware for different applications including:

- MPT1327 Trunked radio systems with MAP27 enabled mobile radios
- TETRA digital radio systems which comply with the ETS 300.392-5 PEI specification
- Digital Cellular systems using GSM AT+C Cellular extensions

The MCU500 hardware is essentially generic and the firmware installed sets the application/use. It is important to have the correct firmware, documentation and programming utilities for your application.

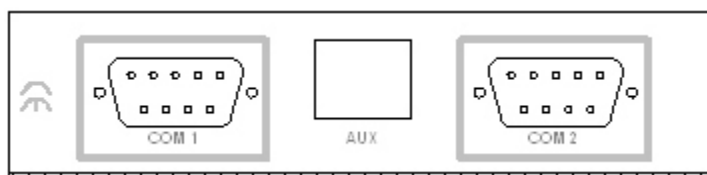

3. Installation and operation

3.1 Installation

The locator unit is designed for installation in the vehicle in a convenient location, for example under the passenger seat, in the boot or behind a bulk-head.

The MCU500 may be operated in any orientation. The front and rear panels have fixing holes to permit the unit to be fixed to a flat surface. Sufficient room (approximately 75-80mm) should be left to allow access the connectors on the front/rear panels.

3.2 Power connection

The following diagram shows the MCU500 power and I/O connector when

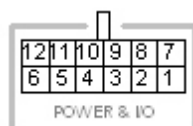

viewed from outside the MCU500

The power supply to the unit is provided via the 12-way Molex connector (Molex part number 39-01-2120) on the front panel.

Thorcom cable (part number 70-00169) for power supply only is available with three pins pre-wired with 3m long leads as follows:

Pin	Name	Colour	Description
1	GND	Black	Ground: connect to a suitable negative supply point
2	VIN	Red	Power input: normally connected to an un-switched (permanent) source of +12V (or +24V depending on model). The power lead should be fused (1A fuse) close to the source.
3	IGN	Yellow	Ignition sense: a voltage of more than 3V causes the unit to switch on - the unit switches off under software control at the appropriate time

If the unit is to be supplied from a switched power source then the red and yellow lines should be joined together and connected to the switched source. Note that in this configuration not all of the features of the unit will be available.

Note: The relays fitted to the MCU500 are capable of switching a maximum of 10

Amps. Ensure that the cable ratings selected match the switched current.

See section 4 for the complete description of the pin-outs of the remaining pins on the Molex connector

3.3 Connection to radio communications equipment

In the vast majority of cases the radio communications equipment will present a standard 9-way female (DB9F) connector, or will have a special cable which ends in a standard 9-way female connector. Where the radio has a standard 9-way connector, a standard RS232 cable (male to female - straight through) can be used to connect COM2 of the MCU500 to the radio device. Thorcom can supply this cable if required, Thorcom part number 70-00167.

If the manufacturer of the radio device provides a special cable from the radio transceiver to a PC/laptop serial port, this cable can probably be used with the MCU500. (The 9-way ports on the MCU500 are pin-compatible with standard PC serial COM ports).

Please consult sections 4 and 8 regarding pinouts of the connector and jumper settings and/or contact Thorcom for availability of ready made connectors.

3.4 GPS antenna selection

The MCU500 has an SMB RF connector on the front panel for connection to a GPS antenna. The GPS receiver is qualified for use with three antennas supplied by Thorcom. Other GPS antennas may be used (see 3.4.2 for technical requirements).

3.4.1 Standard GPS antennas

A range of GPS antennas are available from Thorcom, these are manufactured by Trimble and have been formally qualified for use with the GPS receiver module inside the MCU500.

Type	Description	Part No.
Hard mount	Antenna for permanent installation on the roof of a vehicle or other flat/horizontal surface. Requires single 18mm hole. TNC RF connector. Requires separate RF cable to radio modem (see table below).	50-00001

Type	Description	Part No.
Mag mount	Magnetic mount antenna for temporary use on a vehicle. Supplied with integral 5m long RG174 RF cable and SMB plug for connection to the radio modem.	50-00002

The Hard Mount antenna is most frequently used in permanent vehicle installations - this antenna has a TNC RF socket and requires a separate cable to connect it to the MCU500. The following cables are available:

Part Number	Description
70-00103	TNC to SMB, RG188 PTFE co-axial cable, 2m long
70-00122	TNC to SMB, RG188 PTFE co-axial cable, 5m long

Other lengths are available to special order - please enquire.

3.4.2 Alternative GPS antennas

A wide range of GPS antennas are available on the market, some of which may be used with the MCU500. The MCU500's internal GPS receiver module requires a standard antenna on the GPS L1 frequency (1575.42MHz) with an active pre-amplifier with 26dB gain powered from 5V DC from the cable. A "passive" antenna cannot be used with the MCU500.

The antenna should draw approximately 20-50mA in order that the internal "antenna fault" alarm is not operated. Low loss (small diameter) cable (RG174 or RG188) may be used up to 5m long. The cable should be terminated in an SMB 50ohm plug for connection to the MCU500.

Several companies, for example Panorama Antennas Limited (<http://www.panorama.co.uk>), manufacture dual-band combined antennas for operation as GPS+GSM and GPS+TETRA. These antennas have been found to work with the MCU500 and can be ordered with the correct connectors fitted.

Panorma Part Number	Description
GPSK-SMB-S2-5B	GPS Kombi TETRA 410-430 MHz 6m GPS cable with SMB fitted, 5m TETRA cable BNC fitted
GPSK-SMBP-DE-5F	GPS Kombi 800/900/1800/1900 6m GPS cable with SMB fitted, 5m Cellular cable FME fitted

Panorma Part Number	Description
GPSM-SMBP	GPS only mag-mount, 6m cable, SMB fitted
GPSP-SMBP	GPS only panel mount 6m cable, SMB fitted

4. Interfaces and connectors

The MCU500 has a total of five external connectors as follows:

Port	Connector	Usage
Power & I/O	12-way Molex multi-pole	Connection of power, ignition control, digital inputs and outputs
COM1	9-way D-type male	Serial communications port for connection of optional mobile data terminal (MDT), computer (PC) or personal organiser (PDA) device
COM2	9-way D-type male	Serial communications port for connection of radio communications network device
AUX	8-way RJ45 socket	Auxiliary connector for RS485 serial port, analogue input and additional digital inputs
GPS	SMB RF socket	Antenna connector to the internal GPS receiver

4.1 Power and input/outputs

This connector is a 12-way Molex connector and provides connections for power, ignition sense, digital inputs and relay outputs as follows:

Pin	Name	Description
1	GND	Ground connection (negative)
2	VIN	Un-switched power supply input (12V or 24V depending on model)
3	IGN	Ignition sense input (voltage above 3V causes the unit to switch on)
4	IN1	Input 1 - ground to operate
5	IN2	Input 2 - ground to operate
6	IN3	Input 3 - ground to operate
7	RL1NO	Relay 1 - normally open contact
8	RL1COM	Relay 1 - common contact
9	RL1NC	Relay 1 - normally closed contact
10	RL2NO	Relay 2 - normally open contact

Pin	Name	Description
11	RL2COM	Relay 2 - common contact
12	RL2NC	Relay 2 - normally closed contact

The standard power lead provided with MCU500 has the first three pins wired.

The Molex receptacle, part number 39-01-2120, mates with the MCU500 and additional crimp contacts can be used to wire the additional connections (use Molex part number 39-00-0039 for 3A connections).

4.2 COM1 serial port

The primary serial port (COM1) is provided on a standard DB9 male connector, configured as a DTE with a pin-out which is compatible with an IBM PC/AT serial port:

Pin	Name	Description
1	DCD	Data Carrier Detect (input)
2	RXD	Receive Data (input)
3	TXD	Transmit Data (output)
4	DTR	Data Terminal Ready (output)
5	GND	Ground
6	N/C	No connection
7	RTS	Request To Send (output)
8	CTS	Clear To Send (input)
9	N/C	No connection

The primary serial port (COM1) operates at standard RS232/CCITT V.24 voltage levels and is intended for the connection of a mobile data terminal, in vehicle PC or similar. This primary serial port is also used for programming the unit. A 9-way female to 9-way female (cross-over) cable is needed to connect MCU500 to COM port on a PC. Use Thorcom cable 70-00168 or similar.

4.3 COM2 serial port

The secondary serial port (COM2) is provided on a standard DB9 male connector, configured as a DTE with a pin-out which is compatible with an IBM PC/AT serial port:

Pin	Name	Description
1	DCD	Data Carrier Detect (input)
2	RXD	Receive Data (input)
3	TXD	Transmit Data (output)
4	DT R	Data Terminal Ready (output)
5	GN D	Ground
6	N/C	No connection
7	RTS	Request To Send (output)
8	CTS	Clear To Send (input)
9	MBUS	Nokia Message Bus (MBUS)

The secondary serial port operates at standard RS232/CCITT V.24 voltage levels, TTL/CMOS 5V levels or inverted TTL/CMOS levels, selected by internal jumpers. This allows the communications port to be used with a wide range of data communications providers/devices including those with TTL/CMOS voltage levels.

In addition to these signal levels it is possible to configure the secondary serial port to work with the Nokia Message Bus (MBUS) protocol used on many of Nokia's GSM mobile phones and Tetra radios.

WARNING: due to the nature of the secondary channel's ability to switch between TTL/CMOS and RS232 levels it is possible to connect an RS232 device to the MCU500 while it is configured for TTL/CMOS input/output - this may damage the unit. Do not change the port settings from the factory default (RS232) unless you are sure that the voltage levels are correct for both devices.

4.4 Auxiliary port

The AUX port is a standard 8-way RJ45 socket which provides a third RS232 or RS485 serial port and access to a number of other inputs and outputs:

Pin	Name	Description
1	IN4/AO1	Digital input #4 or auxiliary output #1 (jumper selectable)
2	IN5/AO2	Digital input #4 or auxiliary output #1 (jumper selectable)
3	BUSB+	COM3 RS485 port TxD
4	BUSA+	COM3 either RS232 TxD or RS485 port RxD (jumper selectable)
5	BUSB-	COM3 RS485 port TxD
6	BUSA-	COM3 either RS232 RxD or RS485 port RxD (jumper selectable)
7	IN6/RTCM	Digital input #6 or RTCM-SC104 RS232 differential correction data input to GPS receiver (jumper selectable)
8	GND	Ground

Notes:

1. The RS485 port may be operated in half-duplex or full-duplex mode
2. The RS485 convertor may be disabled and direct connections made using RS232 logic levels
3. Pin 7 may be used to provide differential correction data using standard RTCM-SC104 at 4800bps with standard RS232 voltage levels

WARNING: due to the nature of the Aux port's serial channel it is possible to configure it for TTL/CMOS operation - do not connect RS232/V.24 signals to this port as this may cause damage to the CPU.

4.5 GPS antenna connector

The GPS antenna connector is a 50 ohm SMB RF socket. Connect a suitable 26dB gain active GPS antenna to this connector.

See section 3.4 for information on appropriate antennas.

5. Maintenance and trouble shooting

The MCU500 is not designed to be serviced in the field in respect of component replacement and fault finding, however the following notes may be of use.

5.1 Removing the PCB from the case

The PCB may need to be removed from the case to alter a jumper setting or change the firmware EPROM/FLASH device. Use the following procedure:

- a. disconnect the GPS antenna and power connector from the front of the unit.
- b. undo and remove the nut on the SMB connector (front panel).
- c. undo and remove the four corner screws on the rear panel.
- d. slide out the PCB (the rear panel will remain attached). Take care to save the small washer fitted behind the GPS connector internally, and replace when reassembling.

To re-assemble the MCU500 follow the same procedures in the reverse order. Do NOT overtighten the GPS antenna nut, finger tight plus ½ turn is sufficient. Over tightening may damage the GPS connector assembly.

WARNING: The MCU500 uses CMOS devices which are sensitive to ESD. Take appropriate precautions, for example using a conductive bench and earthed wrist strap.

5.2 Changing the firmware EPROM/FLASH device

In order to change the EPROM/FLASH device

- a. Remove the modem PCB from the case as described in section 6.1 (above).
- b. Locate the dual in line EPROM/FLASH device at position IC3.
- c. Using an IC extractor tool remove the IC from the socket.

WARNING: never use a screwdriver to “lever” the IC from the socket as it is possible to damage the PCB tracks under the socket.

- d. Fit the new EPROM/FLASH in the socket. If the device has 28 pins then it should be fitted nearest the edge of the PCB so that the spare holes of the

socket are nearest the middle of the PCB.

- e. Check the settings of jumper JP5 for the correct size/type of device.
- g. Re-assemble the case.

5.3 Trouble shooting

The following notes are provided to aid trouble shooting and should be read in conjunction with the software/firmware documentation.

5.3.1 No response from the MCU500

Is the PWR (power on) LED lit? If not check that:

- a) that the power cable is connected
- b) that the power supply is present (eg. fuse not blown)
- c) that the ignition sense line goes on (more than 3V) to power up the unit

If the PWR LED is lit check that:

- d) the cable between the MCU500 and radio/transceiver device is attached

5.3.2 Unit unable to send location updates

Check that the GPS antenna is plugged in. Check that after approximately 20 seconds from turning the power on that the NAV (Navigating) LED flashes on/off once per second.

If the NAV light remains off then there is a problem with the GPS antenna cable or the antenna itself - replace and re-test.

If the unit has been unused for an extended period (several weeks) the almanac data may not be valid which will cause the unit to wait to download a new version of the system almanac. Almanac download takes approximately 12.5-15 minutes to achieve given good coverage (view to the sky). This situation may occur when first installing MCU500 units into vehicles.

5.3.3 Unit not correctly programmed

The MCU500 stores user configuration (its personality) in non-volatile memory. The configuration must be valid for the unit to function correctly. If, at power up, the unit's configuration is found to be incorrect (ie. missing or corrupt) the SVC led flashes indicating that the unit requires programming.





The user configuration (personality) is programmed using the Modem Personality Programmer (MPP) software.

6. Jumpers and configuration options

The MCU500 has a number of push on jumpers which configure operation of the unit. The jumpers and settings vary according to the use of the unit and the make/model of radio transceiver/communications device which it is connected to.

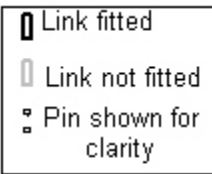
Please refer to the release notes/documentation for the specific application firmware to ensure that the jumpers and adjustments are set correctly for your application.

The MCU500 has the following user selectable jumpers:

Jump er	Name	Description
JP3	COM2 Settings	Select the voltage levels of COM2 between RS232, TTL and Inverted TTL
JP4	Input 2 Mode Select	Select between analogue or digital sense on input 2
JP5	EPROM Settings	Select EPROM size and between Standard EPROM or FLASH EPROM
JP6	RJ45 Mode Select	Select the I/O mode of the auxiliary pins on the RJ45 connector
JP7	Timer Settings	Select the time period between hardware timer wake-up events
		 <ul style="list-style-type: none">  Link fitted  Link not fitted  Pin shown for clarity
JP8	COM3 Settings	Select the voltage levels and bus style between RS232 and RS485



In subsequent link drawings, the following colour scheme is used :

6.1 COM2 voltage settings

The second serial port (COM2 of the MCU500) is used as the interface to the

Most MCU500 units will contain FLASH memory, and these settings will not need to be changed. For users wishing to upgrade to FLASH, these jumpers must be changed at the same time that the EPROM is changed.

With the MCU500 unboxed, and orientated so that the GPS connector is on the right-hand side, JP5 can be found running horizontally just above the EPROM socket (IC3), and to the right of the lithium battery.





EPROM	JP5
27C512 EPROM or 27E512 EEPROM 64K	
29F040 FLASH EPROM	

6.4 RJ45 pin assignments

The MCU500 has more I/O capability than actual physical connections, and so to remain as flexible as possible it is possible to change the mode of some of the pins on the RJ45 connector to match specific application requirements.

The table below shows each RJ45 connection separately, each option can be used in parallel, with up to 3 jumpers fitted in total.



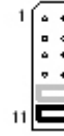

With the MCU500 unboxed, and orientated so that the GPS connector is on the right-hand side, JP6 can be found running vertically just to the right of the RJ45 connector.

JP6					
RJ45 Pin 1		RJ45 Pin 2		RJ45 Pin 7	
					
Input 4	Aux Out 1	Input 5	Aux Out 2	Input 6	RTCM In

6.5 Hardware wake-up timer

The MCU500 can put itself into deep sleep to conserve power, which is especially useful when running for extended periods on a battery only basis. The MCU500 has the option of running an ultra-low power hardware timer to trigger periodic wake-ups and AVL events.



With the MCU500 unboxed, and orientated so that the GPS connector is on the right-hand side, JP7 can be found running horizontally along the top left-hand side of the PCB.

Time Interval	JP7
2.5 Hours	
5 Hours	
10 Hours	
20 Hours	
40 Hours	

6.6 COM3 RS232/RS485 settings

The MCU500 has a third serial port, that can be used as a three-wire RS232 circuit (TXD/RXD/GND) or as a half-duplex or full-duplex RS485 serial bus connection to other in-vehicle devices. Operation is selected via JP8.

With the MCU500 unboxed, and orientated so that the GPS connector is on the right-hand side, JP8 can be found running vertically to the left of the EPROM (IC3), below the lithium battery.

COM3 Levels	JP8
RJ45 is RS232	
RJ45 is RS485 Full Duplex	

Note: Link 13/14 is effectively a half/full duplex selector

7. Technical specifications

CPU:	Zilog Z80182 at 29.4912MHz
Memory: backup (firmware/software) user settings)	128Kb or 512Kb Static RAM with battery 32Kb-512Kb EPROM or FLASH 2Kb serial I ² C non-volatile RAM (factory and
Status indicators:	4 LEDs for status indication
Serial ports:	COM1: 9-way D-type male, configured as PC/AT compatible port with TXD, RXD, RTS, CTS, DCD, DTR, and GND COM2: 9-way D-type male, configured as PC/AT compatible port with TXD, RXD, RTS, CTS, DCD, DTR, and GND. Voltage selectable between RS232, TTL, Inverted TTL and Nokia M bus COM3: RJ45 with RS232 TXD and RXD only, or half/full duplex RS485
Internal GPS receiver: differential input capability	Trimble ACE-III, with RTCM SC104
Digital inputs:	Six inputs: internally pulled up to +5V via 10K, ground to operate, over/under voltage protected
Relay outputs:	Two relays: Single Pole Change Over (SPCO) rated at 10A (resistive) 5A (inductive)
Power supply: controllable.	12V model (10.0 to 16.0 volts DC input) 24V model (20.0 to 32.0 volts DC input) High efficiency switched mode, software
Power consumption:	1.5 watts (GPS receiver installed) - 12V version
Size:	194mm (D) x 108mm (W) x 33mm (H) excluding connectors

Environmental:

Enclosure to IP54
Operating temperature: -10 to +55 Celsius
Storage temperature: -20 to +70 Celsius
Humidity: 0-90% (non-condensing)

Mean Time Between Failure (MTBF): 70,000 Power On Hours (POH)
calculated to MIL-217E

Errors and omissions accepted. Thorcom Systems Limited reserves the right to amend or alter the specification of this product in line with its policy of continued development and improvement.

7.1 Electro-magnetic compatibility and electrical safety

The MCU500 modem has been tested for EMC compliance to:

EN 55022
ETS 300-279

Connections to the MCU500 shall be less than 3.0m in length.

The MCU500 complies with the protection requirements of the EMC directive 89/336/EEC providing that it is installed, operated and maintained as specified. The MCU500 modem also meets the requirements of the Low Voltage Directive (EC/73/23).

Full test results for the MCU500 are held by Thorcom Systems Limited and EMC compliance certificates are available on request.